

**BONENG**

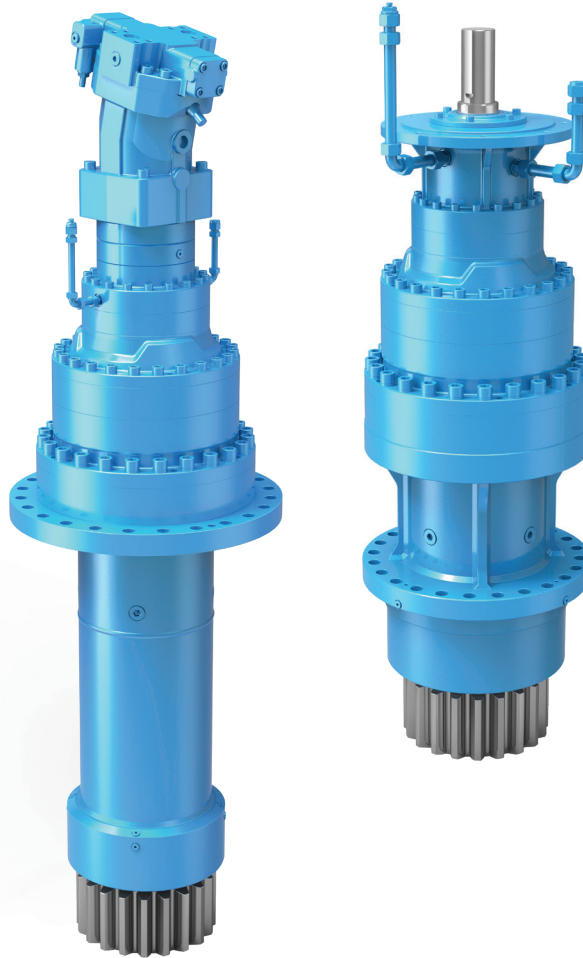

**PS行星回  
转齿轮箱**

**PS Planetary  
Slewing Gearbox**

Edit date 05/2025  
Selection Sample C05.0026

**Boneng Transmission**

Contact : [supplychainalliance.cn@gmail.com](mailto:supplychainalliance.cn@gmail.com)

## PS行星回转齿轮箱

## PS Planetary Slewing Gearbox

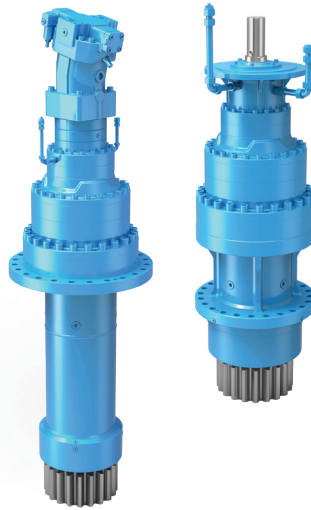

- ◆ PS行星回转齿轮箱是回转机构的理想驱动装置。结构紧凑，性能良好。在繁重工作条件和恶劣环境下能提供卓越的品质和性能，并经过过考验。
  - ◆ 太阳轮、行星轮均采用优质合金钢渗碳淬火处理，内齿圈采用优质合金钢表面硬化处理，所有齿轮均磨齿加工。  
行星架和内齿圈连接法兰均采用球墨铸铁材料，且均通过计算机模拟变形和应力分析等优化设计。
  - ◆ 所有轴承采用知名品牌，轴承系统承载能力高，安全裕度大。
  - ◆ 输入、输出采用径向骨架油封，输出标准结构为双油封设计，在复杂和恶劣的工作环境中具有更高的安全性和更长的使用寿命。
  - ◆ 高度的模块化设计，批量生产更加经济，有效提高供货速度。
  - ◆ 两级、三级和四级行星齿轮传动设计，速比覆盖范围广。
  - ◆ 运转噪音低，传动效率高，使用寿命长。
  - ◆ 安装简单，维护方便。
- ◆ PS planetary slewing gearbox is the ideal drive for the rotation mechanism. Compact structure, good performance. Boneng PS planetary slewing gearbox have proved highly successful under extreme bad operating conditions.
  - ◆ Sun and planet wheels material is excellent alloy steel and processed by carburization and quenching. Internal gear wheel material is excellent alloy steel and processed by hardening. All gears grinding.  
The connection flange of planet carrier and internal gear wheel are made of ductile graphite iron, and are optimized by computer simulation and stress analysis.
  - ◆ All bearings are from famous brand. The bearings have high loading support and safety.
  - ◆ The input and output are protected with radial skeleton seals, the output standard structure is designed for double seals, in complex and harsh working environment with higher safety and longer service life.
  - ◆ High modular design. Volume production is more economic and speeds up the delivery period.
  - ◆ 2 stage, 3 stage and 4 stage design and wide range of ratio.
  - ◆ Low noise, high efficiency and long operation life.
  - ◆ Easy mounting and maintenance.

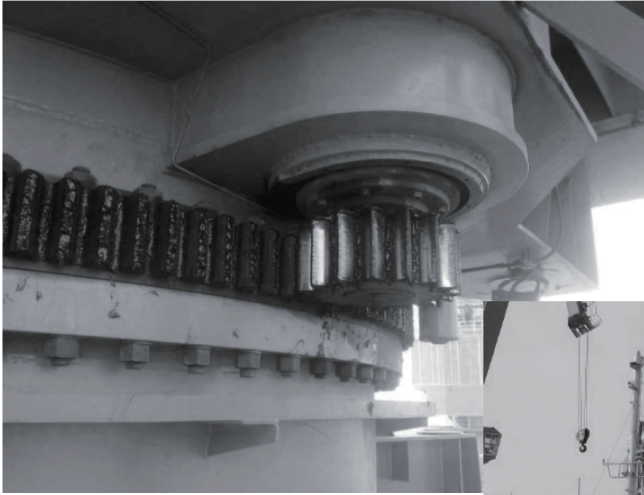
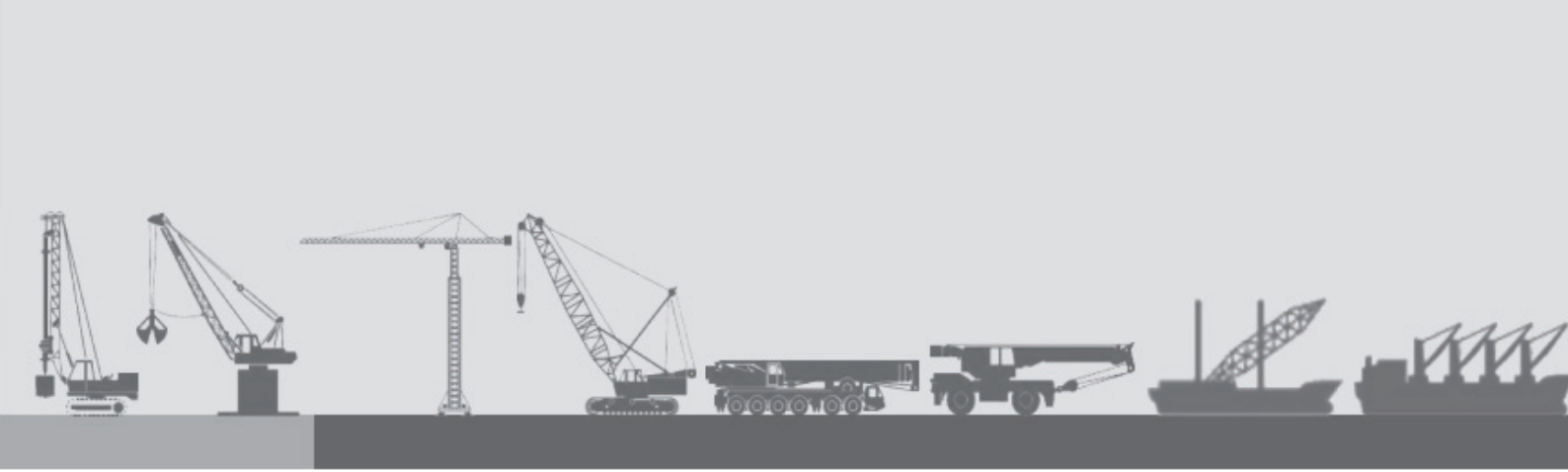

港口起重机和船厂  
船舶和甲板起重机  
海上平台起重机  
随车吊和汽车吊  
拖车和救险车  
旋挖钻和履带式起重机  
建筑起重机和输送设备  
集装箱龙门吊  
装载和转载起重机  
风力发电的偏航变桨机构

博能公司全系列产品采用独创的模块化设计, 零部件通用最大化, 具有量产优势, 标准零配件成本低, 供货周期短, 整个产品系列均采用高制造标准, 保证了极好的承载能力和工作可靠性。

Harbour and dockyard cranes  
Shipboard and deck cranes  
Offshore cranes  
Mobile cranes  
Trailers and rescue vehicles  
Rotary drilling and crawling cranes  
Construction cranes and conveyors  
Container gantries  
Loading and transshipment cranes  
Wind power yaw pitching mechanism

All series products of Boneng use the original modular design, parts general maximization, it has advantage of mass production, the standard parts of low costs, short delivery cycle. The whole product series adopt high manufacturing standards to ensure the excellent carrying capacity and working reliability.

## 注意事项!必须严格遵守以下各项!

## Note: You must conform to the following instructions

- ◆ 样本中的结构示意图、外形图及其他附图只属范例,无严格比例要求。(未注尺寸单位均为mm)。
  - ◆ 所注重量仅为平均值,并不具有约束力。
  - ◆ 为防止意外事故发生,所有旋转部件均按照使用者所在国家和地区的安全规范由购置方加罩保护。
  - ◆ 试车之前必须认真阅读使用说明书。
  - ◆ 齿轮箱在供货时已处于准运行状态,运行前需加注润滑油。
  - ◆ 本样本中注油量只作为参考值,实际注油量应以油尺上的标记为准。
  - ◆ 润滑油粘度应按齿轮箱使用工况及使用环境温度选取。
  - ◆ 只能采用国际知名品牌的润滑油。
- ◆ The structure scheme, appearance diagram and other attached diagrams in sample are examples, there is no strict proportion requirement. (The unmarked dimension units are mm).
  - ◆ We can only refer to the marked weight in the manual.
  - ◆ To prevent accidents, all the rotation parts should be added with protective covers according to local safety regulations and laws.
  - ◆ Before testing, users should read instruction manual carefully.
  - ◆ Gearbox has been tested before delivered, users should add lubrication oil before running.
  - ◆ We can only refer to the marked oil in the manual. Actual oil filling level should be the same with the mark on oil immersion lens.
  - ◆ Lubrication oil viscosity should be selected according to working conditions and the temperature of local environment.
  - ◆ Users can only use high quality lubrication oil.

## 产品功能标识



油 镜



通 气 帽



进 油 孔



放 油 孔



Oil glass



Breather



Oil filler



Oil drain

# 目录

# Contents

01.结构简图 .....	01	01.Design and Construction .....	01
02.型号表示 .....	02	02.Type description .....	02
03.输入方式 .....	02	03.Input modes .....	02
04.产品说明 .....	03	04.Product explanation ..	03
05.选型说明 .....	05	05.Type selection explanation .....	05
06.传动能力 .....	08	06.Transmission capacity .....	08
07.外形尺寸 安装尺寸 .....	09	07.Outline dimensions ..	09
08.安装要求 .....	11	08.Mounting method .....	11
09.润滑说明 .....	12	09.Lubrication .....	12
10.附件 .....	12	10.Accessories .....	12
11.轴端中心孔 .....	13	11.End shaft central hole .....	13
12.平键与键槽尺寸 .....	14	12.SKey and Keyway size .....	14
13.设计参数表 .....	15	13.Parameter table .....	15

## 1 结构简图

## 1 Design and Construction

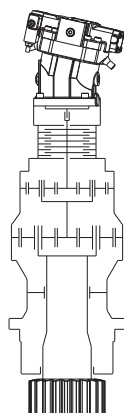
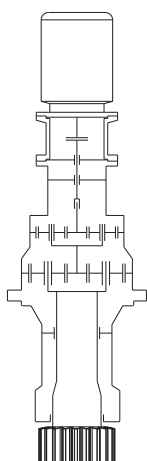

### 二级行星传动齿轮箱

### 2 stage planetary gearbox

额定输出扭矩: 11000至  
150000Nm  
公称减速比14至29  
电动马达/液压马达驱动  
法兰A/法兰B安装  
输入与输出旋转方向相同

Output torques: 11000 to  
150000 Nm  
Ratio from 14 to 29  
Electric motor/ hydraulic  
motor drive  
Flange A/flange B installation  
Input and output in same  
direction of rotation

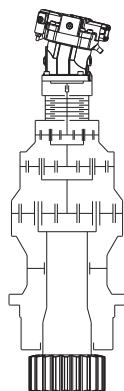
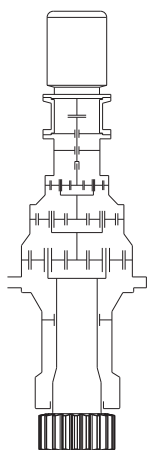

### 三级行星传动齿轮箱

### 3 stage planetary gearbox

额定输出扭矩: 25000至  
230000Nm  
公称减速比46至142  
电动马达/液压马达驱动  
法兰A/法兰B安装  
输入与输出旋转方向相同

Output torques: 25000 to  
230000 Nm  
Ratio from 46 to 142  
Electric motor/ hydraulic  
motor drive  
Flange A/flange B installation  
Input and output in same  
direction of rotation

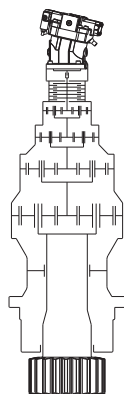
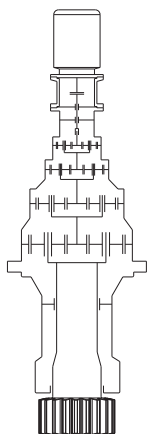

### 四级行星传动齿轮箱

### 4 stage planetary gearbox

额定输出扭矩: 45000至  
590000Nm  
公称减速比171至947  
电动马达/液压马达驱动  
法兰A/法兰B安装  
输入与输出旋转方向相同

Output torques: 45000 to  
590000 Nm  
Ratio from 171 to 947  
Electric motor/ hydraulic  
motor drive  
Flange A/flange B installation  
Input and output in same  
direction of rotation

备注: 各传动级的机械效率为98%, 输出轴轴承及密封圈的机械效率为99%。

例如: 三级行星传动齿轮箱机构的机械效率为 $\eta_{\text{总}}=0.98 \times 0.98 \times 0.98 \times 0.99=0.93$

Remark: Mechanical efficiency of each stage is 98%, output shaft and the seal rings mechanical efficiency is 99%.

For example: the total mechanical efficiency for 3 stage planetary gearbox  $\eta=0.98 \times 0.98 \times 0.98 \times 0.99=0.93$

## 2 型号表示

## 2 Type Description

系列名	PS	行星齿轮传动级数	2级/3级/4级传动	机座号	3	法兰安装形式	法兰A 法兰B	公称减速比	27	输入部分	H-液压马达输入 轴(电机)输入时不标	附件和特殊要求	A - 106 - H + UV32
Series name	PS	Planetary gear transmit stage	2Stage/3Stage/4Stage	Size	3	Flange mounting form	Flange A Flange B	Nominal ratio	27	Input part	Hydraulic motor input Shaft(motor) input without mark	Accessories and special requests	A - 106 - H + UV32

## 3 输入方式

## 3 Input Modes

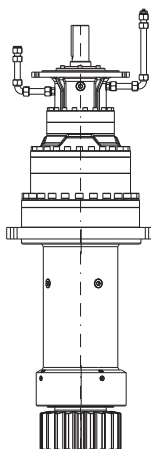

轴(电机)输入, 竖直安装

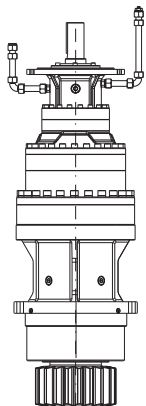

Shaft (motor) input, vertical mounted

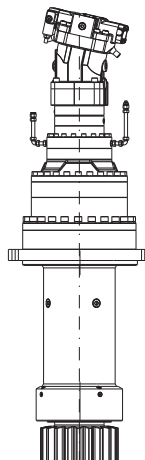

液压马达输入, 竖直安装

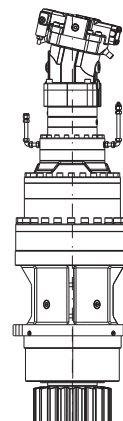

Hydraulic motor input, vertical mounted

产品配备电动机、液压马达两种模块化输入系统。

1) 电机输入时, 根据客户使用要求, 电机和齿轮箱输入轴之间可适配极限力矩限制器/联轴器和工作制动器。当回转部分的外阻力矩超过传动系统的许用扭矩时, 极限力矩限制联轴器打滑, 从而保护传动系统零部件不受损坏; 工作制动器用于工作过程中回转机构的减速或制动, 可采用液压、气动等制动系统。

2) 液压马达输入时, 输入轴为DIN 5480规格的花键轴, 带具有液压松脱—弹簧制动装置的液压多片式驻车制动系统。该制动安全装置是独立的活塞或制动器, 其释放压力最小为15bar, 最大为300bar, 系统残留压力小于0.5bar, 压力管道接口为M12x1.5。

PS with two modular input systems: electric motor input and hydraulic motor input.

(1) When electric motor is input, according to customer's requirements, between motor and gearbox input shaft can fit with ultimate torque limiters/ couplings and operating brake. When the external resistance torque of the slewing section exceeds the permissible torque of the transmission system, the ultimate torque limits the coupling to slip, thus protecting the drive system components from damaging. The working brake is used for deceleration or braking of the slewing mechanism during operation. It can use hydraulic, pneumatic and other braking systems.

(2) When hydraulic motor is input, the input shaft is a DIN 5480 spline shaft, equipped with the hydraulically released spring-action multi-disc brake parking system. This brake safety device is a self contained piston and brake with a minimum release pressure of 15 bar, the maximum pressure is 300 bar. System residual pressure is less than 0.5 bar. The pressure pipe interface is M12X1.5.

## 4 产品说明

### 4.1 偏心距调整:

为了准确地调整输出轴齿轮与回转支承齿圈之间的齿隙,相对于输出齿轮轴与固定法兰,驱动轴可以是偏心的。其中法兰A安装相应安装孔分布圆和止口偏心距 $e1=2.5mm$ ,法兰B安装相应安装孔分布圆和止口偏心距 $e2=1.5mm$ ,且相应安装法兰有偏心高点标记,以便于识别。如图1、图2。



图1 Figure1



图2 Figure2

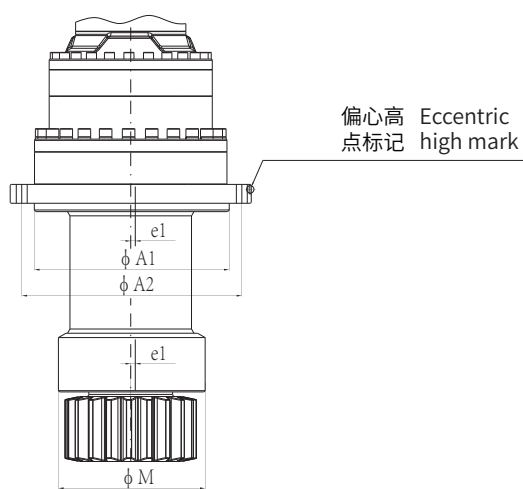

安装法兰分布圆和止口中心 Mounting flange distribution circle and spigot center

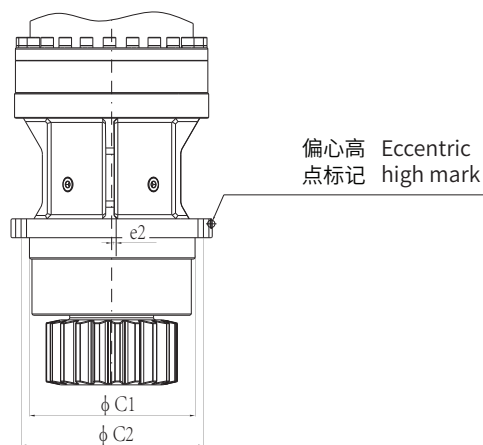
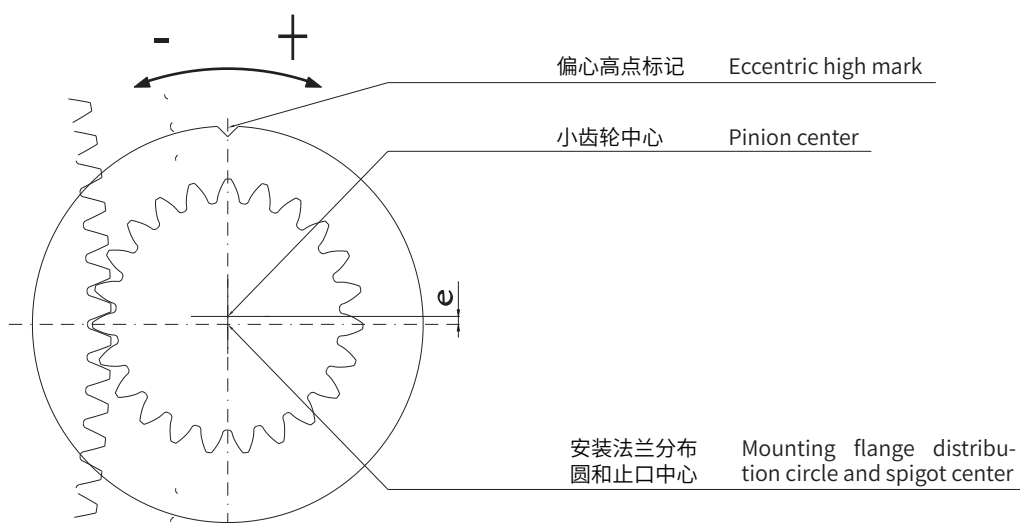

## 4.2 输出法兰回转轴长度和小齿轮

4.2.1 输出法兰A回转轴长度可灵活设计,以满足客户回转支承安装尺寸;

4.2.2 输出端小齿轮参数可灵活设计,具体以客户提供的参数为准;

4.2.3 小齿轮和回转输出轴连接方式: DIN5480花键、平键和一体式设计。

## 4.2 Output flange slewing shaft length and pinion

4.2.1 Output flange A slewing shaft length can be flexibly designed to meet the mounting dimensions of slewing support;

4.2.2 The output pinion parameters can be designed flexibly, depending on the parameters provided by the customer;

4.2.3 Pinion and slewing output shaft connection methods: DIN 5480 splines, parallel keys and one-piece design.

## 4.3 齿轮箱安装方位说明

齿轮箱默认安装方位为垂直方向且小齿轮朝下,若是其余安装位置请事先声明!

## 4.3 Gearbox mounting position instructions

The default mounting position of the gearbox is vertical and the pinion is facing down, if using other mounting positions please declare in advance.

## 5 选型说明

### 5.1 使用说明

PS行星齿轮箱额定动态输出扭矩  $T_{dyn \max}$ 按欧洲起重机械联合会标准FEM (FEM-Federation Europeenne de la Manutention)第三版第一章,驱动机构等级M5,负载分组L2 (P=常数, =15rpm),工况等级T5分组,工作环境温度+20°C设计。客户在计算输出扭矩时,注意回转机构加速、减速、风力及倾斜度。回转齿轮箱输出齿轮的最大扭矩的确定只能根据对整套设备的精确定解。如果回转机构分级为其它工作级别,则其所需输出扭矩必须采用系数K进行修正。

$S_{MF}$  = 摩擦力产生的最大惯性力矩  
 $S_{MW8}$  = 80N/m<sup>2</sup>风力产生的最大扭矩  
 $S_{MS}$  = 倾斜产生的最大扭矩  
 $S_{MA}$  = 加速产生的最大扭矩  
 $S_{MW25}$  = 250N/m<sup>2</sup>风力产生的最大扭矩  
 $Y_m$  = 机械组参数的负载放大系数(见FEM-34)

无风力影响的正常运行

$$S_{Mmax I} = (\bar{S}_{MF} + \bar{S}_{MA}) Y_m$$

有风力影响的正常运行

$$S_{Mmax II} = (\bar{S}_{MF} + \bar{S}_{MA} + \bar{S}_{MW8}) Y_m$$

$$S_{Mmax II} = (\bar{S}_{MF} + \bar{S}_{MW25}) Y_m$$

有风力影响和倾斜角度的正常运行

$$S_{Mmax II} = (\bar{S}_{MW8} + \bar{S}_{MS}) Y_m$$

$T_2$ : 输出扭矩 (N·m)

$T_{2K}$ : 修正后的输出扭矩 (N·m)

K: 工况系数 (设备分组工况系数)

$$T_{2K} = T_2 \cdot K$$

齿轮箱选型时  $T_{2K}$  必须  $< T_{dyn \max}$  (设计扭矩或样本扭矩)

## 5 Type selection explanations

### 5.1 Operation instruction

PS planetary gearbox rated dynamic output torques  $T_{dyn \max}$  are based on FEM standards section 1, 3rd edition (FEM-Federation Europeenne de la Manutention). Drive unit group M5, load conditions L2 (P=constant, =15rpm), running time classification T5. Ambient temperature +20°C. When the customer calculates the output torques, pay attention to the slewing mechanism accelerates, decelerates, winds and inclines. The maximum torque of the slewing gearbox output gear can only be determined by the exact understanding of the equipment. If the slewing mechanism is classified as other working grades, the output torques must be multiplied by the factor K.

$S_{MF}$  = the maximum moment of inertia produced by friction

$S_{MW8}$  = the maximum torque generated by 80N/m<sup>2</sup> wind

$S_{MS}$  = the maximum torque generated by the slope

$S_{MA}$  = the maximum torque generated by the accelerate

$S_{MW25}$  = the maximum torque generated by 250N/m<sup>2</sup> wind

$Y_m$  = Load amplification factor for mechanical group parameters (see FEM-34)

No wind impact of the normal operation

$$S_{Mmax I} = (\bar{S}_{MF} + \bar{S}_{MA}) Y_m$$

With wind impact of the normal operation

$$S_{Mmax II} = (\bar{S}_{MF} + \bar{S}_{MA} + \bar{S}_{MW8}) Y_m$$

$$S_{Mmax II} = (\bar{S}_{MF} + \bar{S}_{MW25}) Y_m$$

With wind impact and slope of the normal operation

$$S_{Mmax II} = (\bar{S}_{MW8} + \bar{S}_{MS}) Y_m$$

$T_2$ : Output torque

$T_{2K}$ : Corrected output torque

K: Application factor (equipment grouping factor)

$T_{2K}$  must  $\leq T_{dyn \max}$  (design torque or sample torque)

### 5.2 工况系数 (机构利用等级和载荷状态分级)

### 5.2 Application factor (running time classification and load conditions)

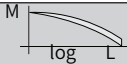
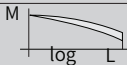
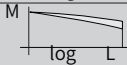
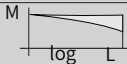
Running time classification 工况等级	运行时间级别	Symbol	T2	T3	T4	T5	T6	T7	T8	
		一年内, 日平均工作时间 (小时)	Mean running time per day in hours, related to one year	0.25—0.5	0.5—1	1—2	2—4	4—8	8—16	>16
	使用寿命 (小时) 8年, 200天/年	Life in hours 8 years, 200 days/year	400—800	800—1600	1600—3200	3200—6300	6300—12500	12500—25000	25000—50000	
Load conditions 负载情况	集合系数	Collective coefficient Km	设备分组工况系数K				Drive unit class Application factor K			
L1		-0.125	M1 0.90	M2 0.90	M3 0.90	M4 0.92	M5 0.92	M6 1.1	M7 1.36	
L2		0.125—0.250	M2 0.90	M3 0.92	M4 0.96	M5 1	M6 1.07	M7 1.3	M8 1.6	
L3		0.250—0.500	M3 1.05	M4 1.09	M5 1.17	M6 1.23	M7 1.28	M8 1.53	M8 1.89	
L4		0.500—1.000	M4 1.32	M5 1.36	M6 1.46	M7 1.53	M8 1.58	M8 1.8	M8 2.22	

### 5.3 起重机械典型载荷谱 (图3)

### 5.3 Typical load spectrum for crane (figure 3)



图3 起重机械典型载荷谱

Figure 3 Crane load spectrum

5.4设备分级指导 参见  
FEM标准第三版第一章,  
表T.2.1.3.5

5.4 Classification guidance  
According FEM section 1,  
3rd edition,table T.2.1.3.5

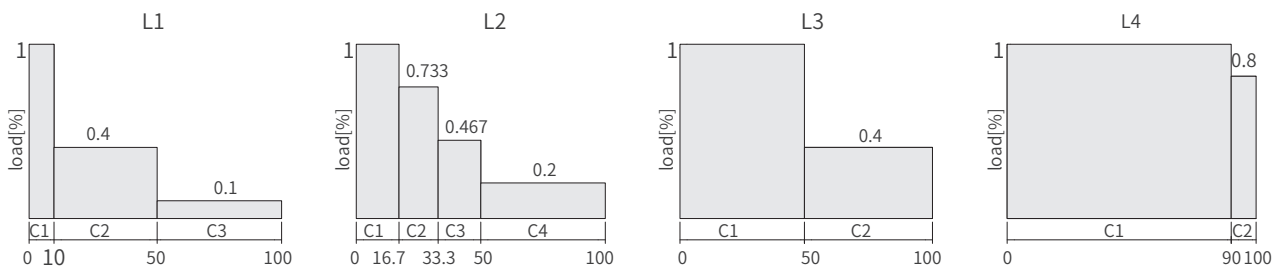
起重机类型 Type of crane(name)	工作元件 Working accessories	驱动机构类型 Type of mechanism				
		起升 Hoisting	回转 Slewing	变幅 Luffing	小车运行 Traverse	大车运行 Travel
安装用起重机 Erection crane		M2-M3	M2-M3	M1-M2	M1-M2	M2-M3
桥式起重机 Bridge crane	吊钩 Hook	M5-M6	M4	-	M4-M5	M5-M6
桥式起重机 Bridge crane	抓斗或 Grab or 磁铁 magnet	M7-M8	M6	-	M6-M7	M7-M8
车间用起重机 Workshop crane	抓斗或 Grab or 磁铁 magnet	M6	M4	-	M4	M5
天车, 夯锤起重机, 废钢场起重机 Crane, Ram crane, Scrap mill crane	吊钩或 Hook or 磁铁 magnet	M8	M6	-	M6-M7	M7-M8
卸料桥, 集装箱 用门式起重机 Unloading bridge, Container gantry crane	吊钩 Hook	M6-M7	M5-M6	M3-M4	M6-M7	M4-M5
其它门式起重 机(带小车和/ 或转台) Other gantry crane(with crab and/or slewing jib crane)	抓斗或 Grab or 磁铁 magnet	M4-M5	M4-M5	-	M4-M5	M4-M5
卸料桥, 集装箱 用门式起重机(带 小车和/或转台) Unloading bridge, Container gantry crane (with crab and/or slewing jib crane)	吊钩 Hook	M8	M5-M6	M3-M4	M7-M8	M4-M5
船台起重机, 船 坞起重机, 拆卸 用起重机 Shipyard crane, Dock crane, Disassembly crane		M5-M6	M4-M5	M4-M5	M4-M5	M5-M6
港口起重机(可 转动, 门式), 浮 式起重机, 浮式 起重架 Harbor crane(slewing, gantry), floating crane and floating derricks	吊钩 Hook	M6-M7	M5-M6	M5-M6	-	M3-M4
港口起重机(可 转动, 门式), 浮 式起重机, 浮式 起重架 Harbor crane(slewing, gantry), floating crane and floating derricks	抓斗或 Grab or 磁铁 magnet	M7-M8	M6-M7	M6-M7	-	M4-M5
浮式起重机和浮 式起重架, 用于 非常高的负荷 (一般在100t以 上) Floating crane and floating derrick for very heavy loads(usually greater than 100t)		M3-M4	M3-M4	M3-M4	-	-
甲板起重机 Deck crane	吊钩 Hook	M4	M3-M4	M3-M4	M2	M3
甲板起重机 Deck crane	抓斗或 Grab or 磁铁 magnet	M5-M6	M3-M4	M3-M4	M4-M5	M3-M4
塔式起重机用于 建筑工地 Tower crane for construction site		M4	M5	M4	M3	M3
门式塔架 Gantry tower		M2-M3	M1-M2	M1-M2	-	-
铁路起重机, 批 准用于铁路维 修 Railway crane, approved for railway maintenance		M3-M4	M2-M3	M2-M3	-	-
车辆起重机 Mobile crane	吊钩 Hook	M3-M4	M3-M4	M2-M3	-	-

备注: 仅列出了回转机构的一些  
典型范围以供参考

Note: Above are only some typical  
applications for slewing mechanism

## 6 传动能力

## 6 Transmission capacity

公称 减速 比	Nomi- nal ratio	精确 减速 比	Exact ratio	型号 PS	Type PS	20	22	24	25	26	27	29	31	32	33	34	36				
iN	iex	T <sub>动</sub> N·m	T <sub>动</sub> N·m			11000	19000	25000	33000	45000	61000	91000	150000	230000	290000	370000	590000				
		T <sub>静</sub> N·m	T <sub>静</sub> N·m			16500	28500	37500	49500	67500	91500	136500	225000	345000	435000	555000	885000				
14	14.11	2 级 Stage	2 级 Stage			☆	☆	☆	☆	☆	☆	☆	☆								
16	16.14					☆	☆	☆	☆	☆	☆	☆	☆	☆	☆						
19	19.22					☆	☆	☆	☆	☆	☆	☆	☆	☆	☆						
21	21.45					☆	☆	☆	☆	☆	☆	☆	☆	☆	☆						
24	24.47					☆	☆	☆	☆	☆	☆	☆	☆	☆	☆						
29	28.79					☆	☆	☆	☆	☆	☆	☆	☆	☆	☆	☆					
46	45.97	3 级 Stage	3 级 Stage			☆	☆	☆	☆	☆	☆	☆	☆	☆	☆						
53	52.56					☆	☆	☆	☆	☆	☆	☆	☆	☆	☆	☆	☆				
60	60.10					☆	☆	☆	☆	☆	☆	☆	☆	☆	☆	☆	☆				
72	71.57					☆	☆	☆	☆	☆	☆	☆	☆	☆	☆	☆	☆				
80	79.88					☆	☆	☆	☆	☆	☆	☆	☆	☆	☆	☆	☆				
85	85.23					☆	☆	☆	☆	☆	☆	☆	☆	☆	☆	☆	☆				
91	91.13					☆	☆	☆	☆	☆	☆	☆	☆	☆	☆	☆	☆				
106	106.18					☆	☆	☆	☆	☆	☆	☆	☆	☆	☆	☆	☆				
121	121.13					☆	☆	☆	☆	☆	☆	☆	☆	☆	☆	☆	☆				
142	142.49					☆	☆	☆	☆	☆	☆	☆	☆	☆	☆	☆	☆				
171	171.21	4 级 Stage	4 级 Stage			☆	☆	☆	☆	☆	☆	☆	☆								
196	195.75					☆	☆	☆	☆	☆	☆	☆	☆	☆	☆	☆	☆	☆	☆	☆	☆
224	223.82					☆	☆	☆	☆	☆	☆	☆	☆	☆	☆	☆	☆	☆	☆	☆	☆
267	266.53					☆	☆	☆	☆	☆	☆	☆	☆	☆	☆	☆	☆	☆	☆	☆	☆
278	277.59					☆	☆	☆	☆	☆	☆	☆	☆	☆	☆	☆	☆	☆	☆	☆	☆
297	297.49					☆	☆	☆	☆	☆	☆	☆	☆	☆	☆	☆	☆	☆	☆	☆	☆
317	317.39					☆	☆	☆	☆	☆	☆	☆	☆	☆	☆	☆	☆	☆	☆	☆	☆
339	339.39					☆	☆	☆	☆	☆	☆	☆	☆	☆	☆	☆	☆	☆	☆	☆	☆
354	354.26					☆	☆	☆	☆	☆	☆	☆	☆	☆	☆	☆	☆	☆	☆	☆	☆
378	377.95					☆	☆	☆	☆	☆	☆	☆	☆	☆	☆	☆	☆	☆	☆	☆	☆
399	399.23					☆	☆	☆	☆	☆	☆	☆	☆	☆	☆	☆	☆	☆	☆	☆	☆
422	421.86					☆	☆	☆	☆	☆	☆	☆	☆	☆	☆	☆	☆	☆	☆	☆	☆
451	451.10					☆	☆	☆	☆	☆	☆	☆	☆	☆	☆	☆	☆	☆	☆	☆	☆
481	481.27					☆	☆	☆	☆	☆	☆	☆	☆	☆	☆	☆	☆	☆	☆	☆	☆
515	514.63					☆	☆	☆	☆	☆	☆	☆	☆	☆	☆	☆	☆	☆	☆	☆	☆
537	537.18					☆	☆	☆	☆	☆	☆	☆	☆	☆	☆	☆	☆	☆	☆	☆	☆
566	566.14					☆	☆	☆	☆	☆	☆	☆	☆	☆	☆	☆	☆	☆	☆	☆	☆
600	599.59					☆	☆	☆	☆	☆	☆	☆	☆	☆	☆	☆	☆	☆	☆	☆	☆
632	631.91					☆	☆	☆	☆	☆	☆	☆	☆	☆	☆	☆	☆	☆	☆	☆	☆
684	684.02					☆	☆	☆	☆	☆	☆	☆	☆	☆	☆	☆	☆	☆	☆	☆	☆
705	705.32	☆	☆	☆	☆	☆	☆	☆	☆	☆	☆	☆	☆	☆	☆	☆	☆				
805	804.65	☆	☆	☆	☆	☆	☆	☆	☆	☆	☆	☆	☆	☆	☆	☆	☆				
848	848.02	☆	☆	☆	☆	☆	☆	☆	☆	☆	☆	☆	☆	☆	☆	☆	☆				
947	946.54	☆	☆	☆	☆	☆	☆	☆	☆	☆	☆	☆	☆	☆	☆	☆	☆				

备注:未注传动比请垂询

Note: For transmission ratios not listed, please contact us.

## 7 外形尺寸 安装尺寸

## 7 Outline dimensions Mounting dimensions

### 法兰A Flange A

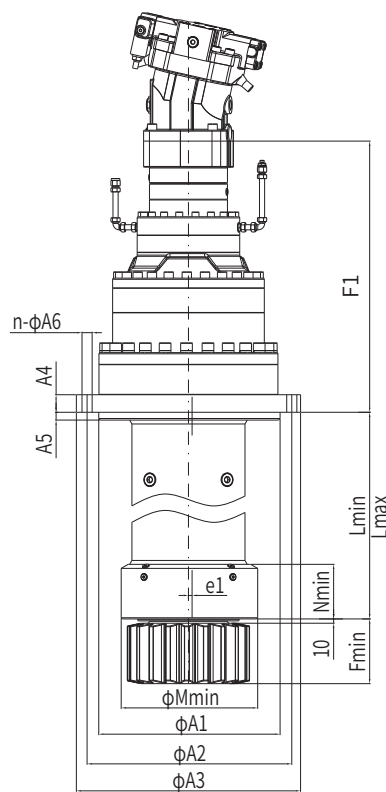
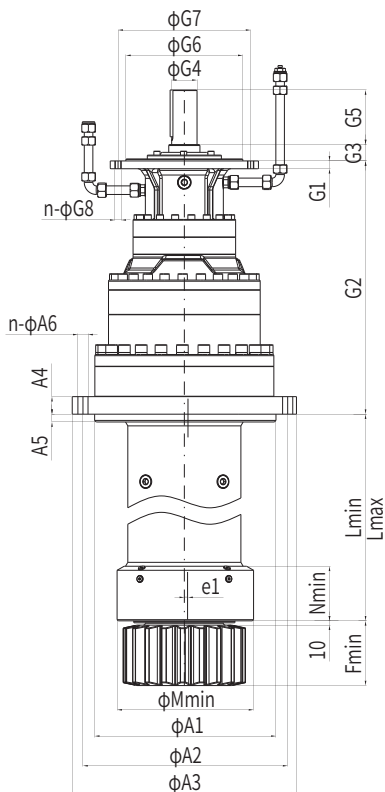

PS	额定输出扭矩 (N.m)		法兰A齿轮箱与钢结构连接螺栓强度等级10.9						The connecting bolt class of flange A gearbox with frame is 10.9					法兰B齿轮箱与钢结构连接螺栓强度等级10.9					The connecting bolt class of flange B gearbox with frame is 10.9					回转输出轴 Slewing output shaft				
	T <sub>动态</sub>	T <sub>静态</sub>	A1	A2 ±0.2	A3	A4	A5	n-A6	C1	C2 ±0.2	C3	C4	C5	n-C6	H1	H2	Lmin	Lmax	Mmin	e1	e2							
20	11000	16500	285h7	325	355	25	20	24-φ13.5	230h7	258	282	25	20	24-φ13.5	75	165	230	1300	220h7	2.5	1.5							
22	19000	28500	320h7	365	395	30	20	24-φ17.5	255h7	345	375	30	20	24-φ17.5	78	175	250	1300	240h7	2.5	1.5							
24	25000	37500	355h7	400	430	30	20	24-φ17.5	280h7	330	368	30	20	24-φ22	100	195	300	1300	270h7	2.5	1.5							
25	33000	49500	390h7	440	475	35	20	24-φ22	280h7	395	430	35	20	24-φ22	100	255	330	1300	270h7	2.5	1.5							
26	45000	67500	430h7	475	515	40	20	24-φ22	365h7	400	440	35	20	24-φ22	100	260	340	1300	330h7	2.5	1.5							
27	61000	91500	465h7	525	575	45	20	24-φ26	395h7	435	480	45	20	24-φ26	185	285	350	1700	340h7	2.5	1.5							
29	91000	136500	550h7	600	660	50	30	24-φ26	435h7	485	540	45	30	24-φ33	190	310	420	1700	380h7	2.5	1.5							
31	150000	225000	630h7	680	740	50	30	24-φ26								450	1700	400h7	2.5									
32	230000	345000	680h7	750	820	55	30	24-φ33								480	1800	450h7	2.5									
33	290000	435000	790h7	850	920	60	40	30-φ33								500	1800	560h7	2.5									
34	370000	555000	850h7	910	980	70	45	36-φ33								650	1800	585h7	2.5									
36	590000	885000	980h7	1070	1160	70	55	36-φ39								720	1800	700h7	2.5									

备注: 1) 液压马达输入详细尺寸依据液压马达型号和制动器选型而定!  
 2) F1, F2尺寸取决于马达/制动器的尺寸, 其余未注尺寸, 请垂询!  
 3) 法兰A回转轴长度按客户要求, 重量仅供参考!

Note: 1) The hydraulic motor input size depends on the hydraulic motor model and the brake selection.  
 2) F1 and F2 depending on the dimensions of the motor brake, For other dimensions not listed, please contact us.  
 3) Flange A slewing shaft length according to customer requirements, weight is for reference only.

法兰B Flange B

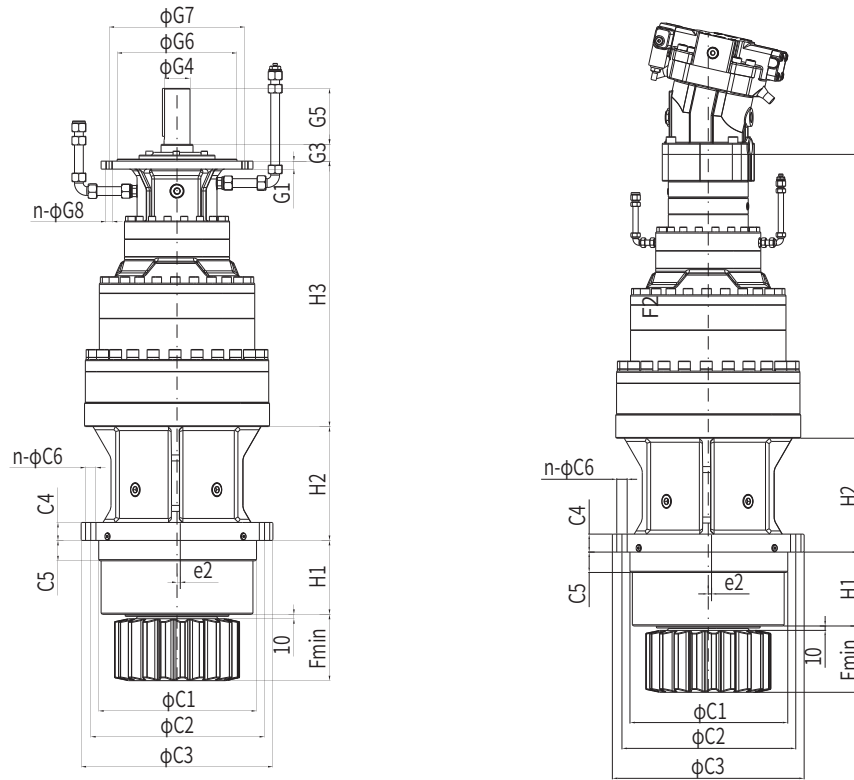

电机驱动 Motor drive															重量 (Kg) Weight (Kg)						PS									
2 级 2 Stage					3 级 3 Stage					4 级 4 Stage					2级2Stage		3级3Stage		4级4Stage											
G2	G3	G4	G5	G6	G7 ±0.2	n-G8	H3	G2	G3	G4	G5	G6	G7 ±0.2	n-G8	H3	G2	G3	G4	G5	G6	G7 ±0.2	n-G8	H3	法兰A FlangeA	法兰B FlangeB	法兰A FlangeA	法兰B FlangeB	法兰A FlangeA	法兰B FlangeB	
402	40	65m6	140	300h7	340	8-M16	412	—	—	—	—	—	—	—	—	—	—	—	—	—	—	—	—	207	179	—	—	—	—	20
414	40	65m6	140	300h7	340	8-M16	424	—	—	—	—	—	—	—	—	—	—	—	—	—	—	—	—	254	226	—	—	—	—	22
490	40	75m6	140	360h7	415	8-M16	515	587	40	65m6	140	300h7	340	8-M16	612	—	—	—	—	—	—	—	—	374	337	417	385	—	—	24
503	40	75m6	140	360h7	415	8-M16	518	599	40	65m6	140	300h7	340	8-M16	614	—	—	—	—	—	—	—	—	410	380	498	419	—	—	25
566	40	95m6	170	450h7	500	8-M16	581	637	40	65m6	140	300h7	340	8-M16	652	702	38	55m6	110	250h7	280	8-M16	717	653	563	735	614	809	675	26
579	40	95m6	170	450h7	500	8-M16	594	650	40	65m6	140	300h7	340	8-M16	665	715	38	55m6	110	250h7	280	8-M16	730	742	689	803	764	914	840	27
694	40	120m6	210	550h7	600	8-M16	724	828	40	95m6	170	450h7	500	8-M16	858	899	40	65m6	140	300h7	340	8-M16	929	1214	1102	1395	1284	1446	1334	29
702	40	120m6	210	550h7	600	8-M16	—	836	40	95m6	170	450h7	500	8-M16	—	906	40	65m6	140	300h7	340	8-M16	—	1575	—	1657	—	1707	—	31
								940	40	95m6	170	450h7	500	8-M16	—	1010	40	65m6	140	300h7	340	8-M16	—	—	—	2164	—	2315	—	32
																1234	40	95m6	170	450h7	500	8-M16	—	—	—	—	—	3063	—	33
																1249	40	95m6	170	450h7	500	8-M16	—	—	—	—	—	3705	—	34
																1314	40	95m6	170	450h7	500	8-M16	—	—	—	—	—	5269	—	36

## 8 安装要求

回转齿轮箱须正确地安装在机械支架上。钢结构的安装中心孔必须同心，并且法兰安装面必须与其垂直。在运行时，中心孔和法兰的相对位置不应该受环境和外力影响。支架构件的制造公差和回转减速机的最大允许变形见下表。

## 8 Mounting Method

The slewing gearbox must be properly mounted on the mechanical support. The mounting center hole of the steel structure must be concentric, and the flange mounting surface must be perpendicular to it. During operation, the relative position of the center hole and the flange should not be affected by the environment and external forces. The manufacturing tolerances of the bracket components and the maximum allowable deformation of the slewing gearbox are shown in the table below.

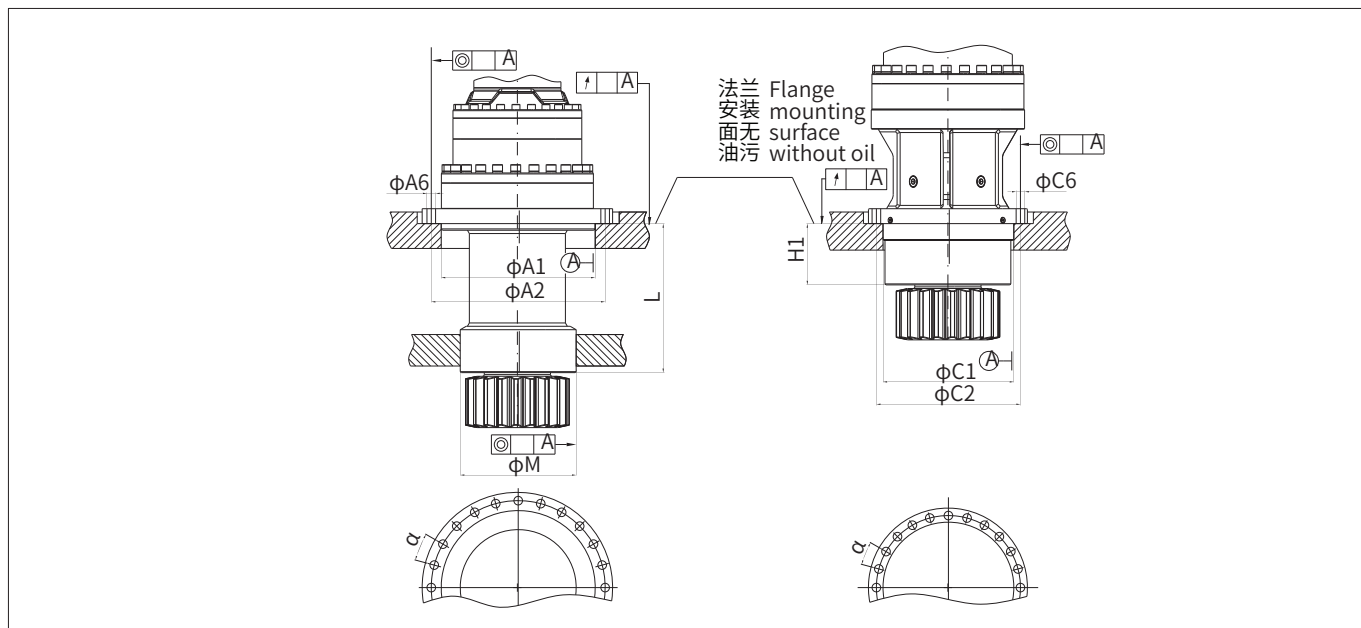

型号 PS	Type PS	在外力作用下的最大允许变形 The maximum allowable deformation under the external forces								中心孔必须同心，允许最大加工误差为 The center hole must be concentric, allowing maximum machining error					回转机构的输出轴不允许由于外力和加工误差的作用产生变形，中心轴最大允许偏差为 The output shaft of the slewing mechanism is not allowed to be distorted by the junction of external force and machining error. The maximum allowable deviation of the central axis is					型号 PS	Type PS
		A1C1	A2C2±	⊙ A	⊥ A	A6	C6	α±	M	输出轴长度 Output shaft length L					输出轴长度 Output shaft length L						
20		0.14	0.2	0.3	0.05	13.5	13.5	15'	0.14	0.05	0.10	0.10	0.10	0.15	0.25	0.30	0.30	0.40	0.40	20	
22		0.16	0.2	0.3	0.07	17.5	17.5	15'	0.16	0.05	0.10	0.10	0.15	0.20	0.30	0.35	0.35	0.50	0.50	22	
24		0.18	0.3	0.5	0.07	17.5	22	10'	0.18	--	0.10	0.10	0.15	0.20	--	0.35	0.35	0.50	0.50	24	
25		0.20	0.3	0.5	0.07	22	22	10'	0.20	--	0.10	0.10	0.15	0.20	--	0.35	0.35	0.50	0.50	25	
26		0.20	0.3	0.5	0.10	22	22	10'	0.20	--	0.10	0.15	0.20	0.25	--	0.40	0.40	0.60	0.60	26	
27		0.23	0.3	0.5	0.10	26	26	10'	0.23	--	0.10	0.15	0.20	0.25	--	0.40	0.50	0.60	0.80	27	
29		0.25	0.3	0.5	0.10	26	33	10'	0.25	--	--	0.15	0.20	0.25	--	--	0.50	0.60	0.80	29	
31		0.25	0.3	0.5	0.10	26	--	10'	0.25	--	--	0.15	0.20	0.25	--	--	0.50	0.60	0.80	31	
32		0.25	0.3	0.5	0.10	33	--	10'	0.25	--	--	0.15	0.20	0.25	--	--	0.50	0.60	0.80	32	
33		0.30	0.3	0.6	0.10	33	--	10'	0.30	--	--	0.20	0.25	0.30	--	--	0.60	0.80	0.80	33	
34		0.30	0.3	0.6	0.10	33	--	10'	0.30	--	--	0.20	0.25	0.30	--	--	0.60	0.80	0.80	34	
36		0.30	0.3	0.6	0.10	39	--	10'	0.30	--	--	0.20	0.25	0.30	--	--	0.60	0.80	0.80	36	

DIN7184规定的形位公差标准定义为：  
工件的中心线必须位于与基准面中心线偏差t=0.2直径的圆柱体内；  
工件在围绕基准线转动时，其加工面的偏差不得超过t=0.2。

The DIN 7184 geometric tolerance standard is defined as:  
The centerline of the workpiece must be in the cylinder with the base line deviation of t=0.2 diameter.  
When the workpiece is rotated around the reference line, the tolerance of the machined surface is not allowed to exceed t=0.2.



## 9 润滑说明

润滑油(重负荷工业齿轮油)粘度牌号选用【VG320(附件代号:UV32)】

## 9 Lubrication

Lubrication viscosity (heavy industrial gear oil) 【VG320 (code: UV32)】

环境温度	Ambient temperature °C	-20°C~+40°C
粘度牌号	Viscosity	VG320

- 注:1.齿轮箱所有轴承采用浸油润滑,除输出轴下端轴承,为脂润滑。  
 2.上表中粘度牌号为40°C温度下的ISO-VG粘度。  
 3.环境温度低于-10°C必须使用合成油。  
 4.为保证产品寿命,实际使用中建议使用合成油。  
 5.若环境温度超出上述范围,敬请垂询。

- Note:1. All bearings of gearbox are lubricated by oil, except for the end of the output shaft bearings is grease lubrication.  
 2. Above table viscosity is only for the temperature under 40°C.  
 3. Ambient temperature below -10°C must use synthetic oil.  
 4. To make sure the long using life, we suggest to use synthetic oil.  
 5. If the ambient temperature is not in the range of table, please contact BONENG.

## 10 附件 ( 具体请垂询 )

- 齿轮箱
- 液压马达
- 电动机
- 力矩限制器/力矩限制联轴器
- 电机安装法兰
- 阀块
- 制动器
- 小齿轮

## 10 Accessories (on request)

- Gearbox
- Hydraulic motor
- Electric motor
- Torque limiter/ torque limit coupling
- Motor mounting flange
- Valve block
- Brake
- Pinion

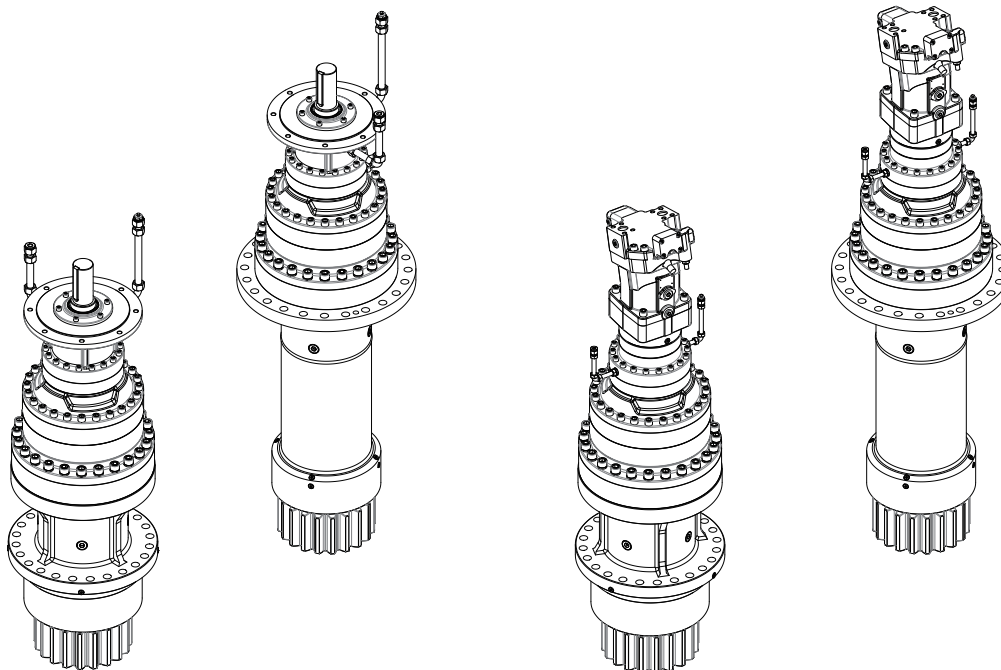

## 11 轴端中心孔

## 11 End shaft central hole

轴端C型螺纹中心孔

C type screw central hole

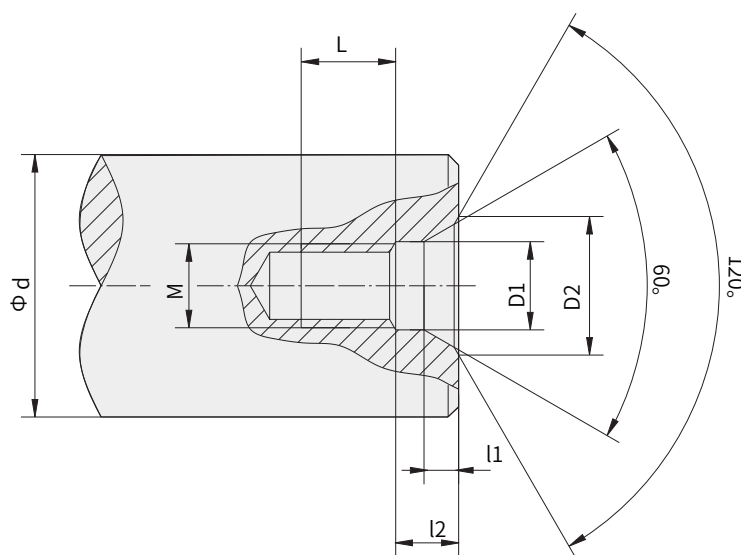

d	M	L	l2	l1	D1	D2
$7 < d \leq 10$	M3	10	2.6	1.8	3.2	5.8
$10 < d \leq 13$	M4	10	3.2	2.1	4.3	7.4
$13 < d \leq 16$	M5	10	4	2.4	5.3	8.8
$16 < d \leq 21$	M6	12	5	2.8	6.4	10.5
$21 < d \leq 24$	M8	12	6	3.3	8.4	13.2
$24 < d \leq 30$	M10	15	7.5	3.8	10.5	16.3
$30 < d \leq 38$	M12	20	9.5	4.4	13	19.8
$38 < d \leq 50$	M16	25	12	5.2	17	25.3
$50 < d \leq 85$	M20	30	15	6.4	21	31.3
$85 < d \leq 130$	M24	35	18	8	25	38
$130 < d \leq 225$	M30	45	18	11	31	48

## 12 平键与键槽尺寸      12 Key and keyway dimension

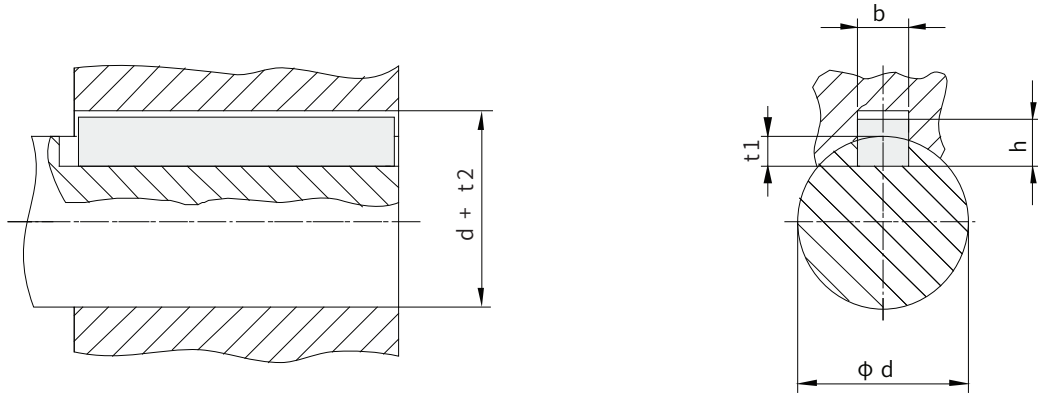

d	b	h	t1	d+t2
8 < d ≤ 10	3	3	1.8	d+ 1.4
10 < d ≤ 12	4	4	2.5	d+ 1.8
12 < d ≤ 17	5	5	3	d+ 2.3
17 < d ≤ 22	6	6	3.5	d+ 2.8
22 < d ≤ 30	8	7	4	d+ 3.3
30 < d ≤ 38	10	8	5	d+ 3.3
38 < d ≤ 44	12	8	5	d+ 3.3
44 < d ≤ 50	14	9	5.5	d+ 3.8
50 < d ≤ 58	16	10	6	d+ 4.3
58 < d ≤ 65	18	11	7	d+ 4.4
65 < d ≤ 75	20	12	7.5	d+ 4.9
75 < d ≤ 85	22	14	9	d+ 5.4
85 < d ≤ 95	25	14	9	d+ 5.4
95 < d ≤ 110	28	16	10	d+ 6.4
110 < d ≤ 130	32	18	11	d+ 7.4
130 < d ≤ 150	36	20	12	d+ 8.4
150 < d ≤ 170	40	22	13	d+ 9.4
170 < d ≤ 200	45	25	15	d+10.4
200 < d ≤ 230	50	28	17	d+11.4
230 < d ≤ 260	56	32	20	d+12.4

## 13 设计参数表

公司名称: \_\_\_\_\_

地址: \_\_\_\_\_

联系人: \_\_\_\_\_

电话: \_\_\_\_\_ 传真: \_\_\_\_\_

应用: \_\_\_\_\_ (举例: 门座起重机、克令吊、汽车吊、船载起重等)

用于: \_\_\_\_\_ (举例: 回转减速等)

工况概述	技术参数
额定输出扭矩: [KNm] 最大动态输出扭矩: [KNm] 静态输出扭矩: [KNm]	输出小齿轮: 模数 m: [mm] 齿数 Z: 齿宽 b: [mm]
输入转速: [m/min] 输出转速: [m/min]	变位系数 X:
公称减速比: 偏心: [mm]	<input type="checkbox"/> 小齿轮分体: <input type="checkbox"/> DIN5480花键连接 <input type="checkbox"/> 平键联接 <input type="checkbox"/> 小齿轮一体 <input type="checkbox"/> 小齿轮齿面高频淬火表面硬化 <input type="checkbox"/> 小齿轮渗碳淬火磨齿
法兰安装形式: <input type="checkbox"/> 法兰 A 输出长轴壳体长度 L: [mm] <input type="checkbox"/> 法兰 B	
安装位置: 输出齿轮 <input type="checkbox"/> 上 <input type="checkbox"/> 下 <input type="checkbox"/> 水平	中心距 A: [mm]

分类按 FEM1.001---ISO4301

设备分组 M: \_\_\_\_\_ 起重等级 L: \_\_\_\_\_ 工作时间等级 T: \_\_\_\_\_

驱动单元

<input type="checkbox"/> 电机驱动: 型号: 功率 P: _____ [KW] 额定转速 n: _____ [rpm] 起动转矩 MA: _____ [Nm] 极限转矩 Tk: _____ [Nm] 起动时间 ED: _____ 每小时起动: _____	<input type="checkbox"/> 液压马达驱动 型号: 有效流量: _____ [L/min] 有效压力差 $\Delta P$ : _____ [bar] 排量 $V_g$ : _____ [cm <sup>3</sup> ]
--	--

制动

类型 <input type="checkbox"/> 驻车制动	应用类型 <input type="checkbox"/> 液压 工作压力最小 _____ [bar] 工作压力最大 _____ [bar]
<input type="checkbox"/> 工作制动	<input type="checkbox"/> 电力/磁力

目前供货范围 (具体请垂询)

- |                               |  |                              |
|-------------------------------|--|------------------------------|
| <input type="checkbox"/> 齿轮箱  | <input type="checkbox"/> 力矩限制器/力矩限制联轴器 | <input type="checkbox"/> 制动器 |
| <input type="checkbox"/> 液压马达 | <input type="checkbox"/> 电机安装法兰        | <input type="checkbox"/> 小齿轮 |
| <input type="checkbox"/> 电动机  | <input type="checkbox"/> 阀块            |                              |

备注和特殊要求: \_\_\_\_\_

### 13 Parameter table

Company name: \_\_\_\_\_

Address: \_\_\_\_\_

Contact: \_\_\_\_\_

Tel: \_\_\_\_\_ Fax: \_\_\_\_\_

Application: \_\_\_\_\_ (e.g. gantry crane, crane, mobile crane, ship offshore harbor crane etc.)

Used for: \_\_\_\_\_ (e.g. slewing deceleration etc.)

Operating condition	Technical data
Rated output torque Tdyn: [KNm]	Output pinion:
Max. dynamic output torque Tdyn max: [KNm]	Normal module m : [mm]
Static output torque Tstat: [KNm]	Number of teeth Z :
	Tooth width b : [mm]
Input speed n1: [m/min]	Modification factor X :
Output speed n2: [m/min]	
Nominal ratio iN:	<input type="checkbox"/> Pinion two-pieces:
Eccentricity: [mm]	<input type="checkbox"/> DIN5480 Spline connection <input type="checkbox"/> Parallel key connection
Flange mounting method: <input type="checkbox"/> Flange A output long shaft [mm]	<input type="checkbox"/> Pinion one-piece
housing length L: <input type="checkbox"/> Flange B	<input type="checkbox"/> Pinion surface high frequency quenching, surface hardening
	<input type="checkbox"/> Pinion quenching, grinding gears
Mounting position: output gear	Center distance A: [mm]
<input type="checkbox"/> Up <input type="checkbox"/> Down <input type="checkbox"/> Level	

Classify as FEM1.001---ISO4301

Drive unit group M: \_\_\_\_\_ The load spectrum L: \_\_\_\_\_ Running time classification T : \_\_\_\_\_

Drive unit

<input type="checkbox"/> electric motor drive:	<input type="checkbox"/> hydraulic motor drive
Type:	Type:
Power P: _____ [KW]	Available oil flow qv: _____ [L/min]
Rated speed n: _____ [rpm]	Available pressure difference ΔP: _____ [bar]
Starting torque MA: _____ [Nm]	Displacement Vg: _____ [cm <sup>3</sup> ]
Breakdown torque Tk: _____ [Nm]	
Starting time ED: _____	
Starting per hour: _____	

Brake

Apply as <input type="checkbox"/> parking brake	Actuation <input type="checkbox"/> hydraulically
	Min. release pressure _____ [bar]
	Max. release pressure _____ [bar]
<input type="checkbox"/> service braking	<input type="checkbox"/> electric/ magnetic

Scope of supply (on request)

- Gearbox
- Torque limiter/ torque limit coupling
- Brake
- Hydraulic motor
- Motor mounting flange
- Pinion
- Electric motor
- Valve block

Remarks and special requests: \_\_\_\_\_

随着技术迭代进步，博能产品样本将会同步更新，请见谅。  
 Along with the technology advancedet.,the product of  
 the manual of Boneng will be changed,please forgive.

控制层 CONTROL

驱动层 DRIVE

马达层 MOTOR

齿轮层 GEAR



X3010 PLC  
EtherCAT&Modbus  
24VDC



X3050 运动控制器  
Motion Controller  
EtherCAT&Modbus  
24VDC

C/F/K/S-M  
\* . . . D  
马达分布式  
变频驱动器  
Integrated  
Gearmotor  
Drive

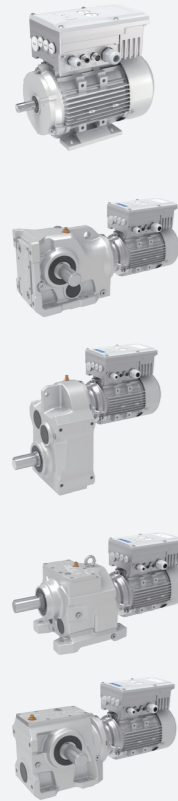

EtherCAT&  
Modbus  
380~480VAC  
0.25~3kW  
i=4~355

AM 变频驱动器  
Variable Frequency Drive



Modbus  
380~480VAC  
0.75~5.5kW

A1 变频驱动器  
Variable Frequency Drive



Modbus/CANopen  
/PROFINET  
380~480VAC  
0.75~250kW

C/F/K/S/R  
齿轮马达  
Gearmotor



380~480VAC  
0.09~200kW  
i=1.25~500

MP/MU/MA  
三相交流异步马达  
Asynchronous Motor



380~480VAC  
0.09~90kW  
960/1450r/min  
1160/1750r/min

HB/BE/HK  
齿轮箱  
Gearbox



4.2~15775kW  
i=5.6~450

P/PK  
行星齿轮箱  
Planetary  
Gearbox



0.4~14000kW  
i=25~4000

PW  
卷扬齿轮箱  
Planetary  
Winch  
Gearbox

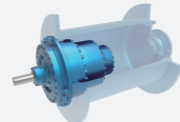

1~1810kW  
i=13~940

PS  
回转齿轮箱  
Planetary  
Slewing  
Gearbox



1~1626kW  
i=14~947

MX&AX  
伺服马达&伺服  
驱动器  
Permanent  
Magnet  
Servo Motor  
& Servo Drive



EtherCAT/  
PROFINET  
380~480VAC  
0.28~14kW  
1500/2000r/min  
3000/4500r/min

C/F/K/S-MX  
&AX齿轮伺  
服马达&伺  
服驱动器  
Servo  
Gearmotor  
& Servo Drive

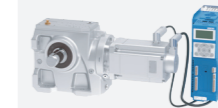
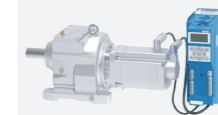
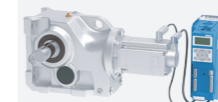

EtherCAT/  
PROFINET  
380~480VAC  
0.28~14kW  
i=1.25~315

PX-MX&AX  
行星伺服马达  
&伺服驱动器  
Planetary  
Precision Gear  
Servo Motor  
& Servo Drive



EtherCAT/  
PROFINET  
380~480VAC  
0.38~14kW  
i=3~100

PN-MN&AN  
行星伺服马达  
&伺服驱动器  
Planetary  
Precision Gear  
Servo Motor  
& Servo Drive



EtherCAT  
380~480VAC  
0.28~5.03kW  
i=3~100